

Implements: p.61

- 1) Boys: Shot Put = 12 lb; Girls: Shot Put = 4 Kg.....6-10-2
 2) Shot Puts may not have indentations other than a weight marking.....6-10-1
 3) Illegal equipment is not allowed during warm-up or competition. If used = Event DQ.....6-2-13

Uniforms: p.23-24

- 4) Competitors must wear shoes fastened securely to both feet.....4-3-1a
 5) Competitors must compete in a complete uniform (school issued or school approved).....4-3-1b

Warm ups: p.42

- 6) Warm-up must be supervised by official or coach and venue declared open.....6-2-6
 7) Once competition begins, venue and associated equipment is off limits for practice.....6-2-8
 8) Event concluded - there will be no further activity - event area is closed.....6-2-9
 1st Violation → Warning ... 2nd Violation → Event DQ ... 3rd Violation → Meet DQ

Order: p.43**Shot Put = Boys 1st [even year]; Girls 1st [odd year]**

- 9) Open order: Games committee will set time limit for prelims.....3-2-4d...6-2-21
 10) Prelim flights of no less than 5 by lot or in the order set by games committee.....6-2-18
 11) Finals Athlete w/least prelim mark is 1st; Athlete w/best prelim mark is last.....6-2-3...6-2-20
 12) Order may be changed in any throwing event to allow for participation in other events.....6-2-3

Grip: p.43; 45

- 13) Chalk or an adhesive such as rosin may be used to assist with grip.....6-2-14
 14) Gloves NOT permitted; Taping adjacent fingers is NOT permitted.....6-4-1
 15) Taping of the wrist is permitted; wrist wrap and/or support belt is permitted.....6-4-1

Trials: p.43; 42

- 16) Larger meets: 3 prelims – 3 finals: all trials count for placing.....6-2-17
 17) Smaller meets: 4 trials – no finals: all trials count for placing.....3-2-4e...6-2-10

Time Limit: Table on p.41; 45; 42

- 18) After being called competitors have one (1) min to initiate a trial.....6-2-2.....6-4-3a
 19) Time limit when excused to other events → determined by games committee.....6-2-4

Measurements: p.52; 45

- 20) Marks are recorded after each LEGAL trial; ONLY measure LEGAL trials.....Mhsaa
 21) SECTOR LINES are out-of-bounds. Puts shall be made from inside the circle.....6-9-2
 22) Measure from nearest edge of mark to inside edge of stopboard thru center of circle.....6-4-4
 23) RECORD LEGAL TRIALS to nearest lesser quarter (¼) INCH or CENTIMETER.....6-4-5

Finals: p.43

- 24) One (1) more competitor advances to finals than places awarded - no substitutions.....6-2-19
 25) If 8 places score, 9 competitors advance to finals plus everyone tied for 9th advance.....6-2-19
 26) There must be at least one qualifying prelim trial for athlete to move on to finals.....6-2-19

Failed Attempts: p.45

- 27) Competitor FAILS TO INITIATE A TRIAL within one (1) minute after name is called..6-2-2...6-4-3a
 28) Once in the circle, Competitor FAILS TO PAUSE before starting the put.....6-4-3b
 29) Competitor TOUCHES ANY SURFACE outside of circle during the put.....6-4-3ce
 30) The SHOT DROPS BEHIND OR BELOW the shoulder.....6-4-3d
 31) A legal put must be made from shoulder with ONE HAND ONLY from inside the circle.....6-4-2
 32) Shot does not fall WITHIN the sector lines.....6-4-3f
 33) Competitor LEAVES THE CIRCLE BEFORE the implement has landed.....6-4-3g
 34) Competitor DOES NOT EXIT BACK HALF of the circle.....6-4-3h
 35) Competitor does a "CARTWHEEL".....6-4-3i

Ties: p.44

- 36) Break ties by comparing 2nd-best efforts. CONSIDER ALL TRIALS.....6-3-2a1
 37) If still tied after comparing 2nd best effort, compare 3rd-best efforts, etc.....6-3-2a2
 38) Ties remaining after this process -
 Add points for places & divide between competitors.....6-3-4

Implements: p.62

- 1) Boys: Discus = 1.6 Kg; Girls: Discus = 1 Kg.....6-10-4
 2) A Discus may not have indentations, projecting points or sharp edges.....6-10-3
 3) Illegal equipment is not allowed during warm-up or competition. If used = Event DQ.....6-2-13

Uniforms: p. 23-24

- 4) Competitors must wear shoes fastened securely to both feet.....4-3-1a
 5) Competitors must compete in a complete uniform (school issued or school approved).....4-3-1b

Warm ups: p.42

- 6) Warm-up must be supervised by official or coach and venue declared open.....6-2-6
 7) Once competition begins, venue and associated equipment is off limits for practice.....6-2-8
 8) Event concluded - there will be no further activity - event area is closed.....6-2-9
 1st Violation → Warning ... 2nd Violation → Event DQ ... 3rd Violation → Meet DQ

Order: p.43**Discus Throw = Girls 1st [even year]; Boys 1st [odd year]**

- 9) Open order: Games committee will set time limit for prelims.....3-2-4d...6-2-21
 10) Prelim flights of no less than 5 in the order set by games committee.....6-2-18
 11) Finals Athlete w/least prelim mark is 1st; Athlete w/best prelim mark is last.....6-2-3...6-2-20
 12) Order may be changed to allow for participation in other events.....6-2-3

Grip: 43; 45

- 13) Chalk or an adhesive such as rosin may be used to assist with grip.....6-2-14
 14) Gloves NOT permitted; Taping adjacent fingers is NOT permitted.....6-5-1
 15) Taping of the wrist is permitted; wrist wrap and/or support belt is permitted.....6-5-1

Trials: p.43; 42

- 16) Larger meets: 3 prelims – 3 finals: all trials count for placing.....6-2-17
 17) Smaller meets: 4 trials – no finals: all trials count for placing.....3-2-4e...6-2-10

Time Limit: Table on p.41; 46; 42

- 18) After being called competitor has one (1) min to initiate a trial.....6-2-2.....6-5-2a
 19) Time limit when excused to other events → determined by games committee.....6-2-4

Measurements: p.52; 46

- 20) Marks are recorded after each LEGAL trial; ONLY measure LEGAL trials.....mhsaa
 21) SECTOR LINES are out-of-bounds. Throws shall be made from inside the circle.....6-9-2
 22) A discus that hits the CAGE or OBJECT outside the sector is a foul.....6-5-2e
 23) Measure from nearest edge of mark to inside edge of circle through its center.....6-5-3
 24) RECORD LEGAL TRIALS to nearest lesser INCH or CENTIMETER.....6-5-4

Finals: p.43

- 25) One (1) more competitors advance to finals than places awarded - no substitutions.....6-2-19
 26) If 8 places score, 9 competitors advance to finals plus everyone tied for 9th advance.....6-2-19
 27) There must be at least one qualifying prelim trial for athlete to move on to finals.....6-2-19

Failed Attempts: p.46

- 28) Competitor FAILS TO INITIATE A TRIAL within one (1) minute after name is called..6-2-2...6-5-2a
 29) Once in the circle, Competitor FAILS TO PAUSE before starting throw.....6-5-2b
 30) Competitor TOUCHES any surface outside of circle during throw.....6-5-2c
 31) Discus does not fall WITHIN the sector lines.....6-5-2d
 32) Discus hits the cage or object outside the sector and bounces back into the sector.....6-5-2e
 33) Competitor LEAVES THE CIRCLE BEFORE the implement has landed.....6-5-2f
 34) Competitor DOES NOT EXIT BACK HALF of the circle.....6-5-2g
 [NOTE: Competitor may enter circle from anywhere]

Ties: p.44

- 35) Break ties by comparing 2nd-best efforts. CONSIDER ALL TRIALS.....6-3-2a1
 36) If still tied after comparing 2nd best effort, compare 3rd-best efforts, etc.....6-3-2a2
 37) Ties remaining after this process -
 Add points for places & divide between competitors.....6-3-4

Landing Area: p.56-57

- 1) Take-off board shall be 8" (recommended) to 24" deep and 42" to 48" wide.....6-9-15
- 2) The landing area should be filled with 12" sand or soft material & level with the board.....6-9-16
- 3) The landing area shall be a minimum of (23) feet long and (9) feet wide.....6-9-17
- 4) Distance from the foul line to pit may be adjusted to accommodate levels of ability.....6-9-17

Uniforms: p.23-24

- 5) Competitors must wear shoes fastened securely to both feet.....4-3-1a
- 6) Competitors must compete in a complete uniform (school issued or school approved).....4-3-1b

Warm ups: p.42

- 7) Warm-up must be supervised by official or coach and venue declared open.....6-2-6
- 8) Warm-up approaches shall only be run in the direction of competition (see NOTE).....6-2-7
- 9) Once competition begins, venue and associated equipment is off limits for practice.....6-2-8
- 10) Event concluded - there will be no further activity - event area is closed.....6-2-9
 - 1st Violation ➔ Warning ... 2nd Violation ➔ Event DQ ... 3rd Violation ➔ Meet DQ

Order: p.41-43**Long Jump = Girls 1st [even year], Boys 1st [odd year]**

- 11) Open order: Games committee will set time limit for prelims.....3-2-4d...6-2-21
- 12) Prelim flights of no less than 5 by lot or in the order set by games committee.....6-2-18
- 13) Finals Athlete w/least prelim mark is 1st; Athlete w/best prelim mark is last.....6-2-3.....6-2-20
- 14) Order may be changed in any jumping event to allow for participation in other events.....6-2-3

Check marks: p.13

- 15) The type material used for check marks is determined by the games committee.....3-2-4b
- 16) Check marks are not allowed on the runway or in the landing pit.....6-7-1
- 17) ONE or TWO **approved** markers may be placed alongside the runway.....6-7-1a

Trials: p. 43; 42

- 18) Larger meets: 3 prelims – 3 finals: all trials count for placing.....6-2-17
- 19) Smaller meets: 4 trials – no finals: all trials count for placing.....3-2-4f...6-2-10

Time Limit: Table on p.41; 42; 47

- 20) After being called competitors have one (1) min to initiate a trial.....6-2-2.....6-7-3f
- 21) Time limit when excused to other events ➔ determined by games committee.....6-2-4

Failed Attempts: p.47

- 22) Any part of the shoe violates the foul line.....6-7-3a
- 23) Competitor runs through the foul line or foul line extended.....6-7-3b
- 24) Competitor does not keep head in superior position. [NO somersault].....6-7-3c
- 25) Competitor does not land in the pit.....6-7-3e
- 26) When leaving the pit, competitor touches the ground outside the landing area closer to the foul line than the nearest mark made in the sand.....6-7-3e
- 27) Competitor fails to initiate a trial within one (1) minute after name is called.....6-2-2.....6-7-3f

Measurements: p.48

- 28) Measure marks from nearest edge of landing mark perpendicularly to the foul line.....6-7-4
- 29) The foul line may need to be extended to ensure a perpendicular measurement.....6-7-4
- 30) Measurements of trials shall be taken at the takeoff board.....6-7-5
- 31) ONLY measure LEGAL trials. RECORD to nearest LESSER ¼ INCH or CENTIMETER.....6-7-6

Finals: p.43

- 32) One (1) more competitor advances to finals than places awarded - no substitutions.....6-2-19
- 33) If 8 places score, 9 competitors advance to finals plus everyone tied for 9th advance.....6-2-19
- 34) There must be at least one qualifying prelim trial for athlete to move on to finals.....6-2-19

Ties: p.44

- 35) Break ties by comparing 2nd-best efforts. CONSIDER ALL TRIALS.....6-3-2a1
- 36) If still tied after comparing 2nd best effort, compare 3rd-best efforts, etc.....6-3-2a2
- 37) Ties remaining after this process -
 - Add points for places & divide between competitors.....6-3-4

Landing Area: p.57

- 1) Landing pads in sections must be attached and encased in a COMMON COVER.....6-9-20
- 2) Bordering surfaces (concrete/asphalt) shall be padded 2" min. dense foam material.....6-9-21
- 3) Support bases shall be marked as to their location at the start of competition.....6-9-22
- 4) Mark the X-Bar and base of the standards in exactly the same position before displacement.....6-8-12
- 5) High Jump crossbar shall be circular, non-metal and 12' to 14'10" in length.....6-9-23

Uniforms: p.23-24

- 6) Competitors must wear shoes fastened securely to both feet.....4-3-1a
- 7) Competitors must compete in a complete uniform (school issued or school approved).....4-3-1b

Warm ups: p.42

- 8) Warm-up must be supervised by official or coach and venue declared open.....6-2-6
- 9) Once competition begins, venue and associated equipment is off limits for practice.....6-2-8
- 10) Event concluded - there will be no further activity - event area is closed.....6-2-9
 - 1st Violation ➔ Warning ... 2nd Violation ➔ Event DQ ... 3rd Violation ➔ Meet DQ
- 11) Bungee cord crossbars may be used for warm-up jumps.....6-8-3

Order: p.43; 48**High Jump = Boys 1st [even year], Girls 1st [odd year]**

- 12) Calling contestants in listed order or using the "Five-Alive" system is allowed.....6-8-2
- 13) When less than 9 remain at a height, ALL will move to a single continuing flight.....6-8-2
- 14) Order may be changed in any jumping event to allow for participation in other events.....6-2-3

Check marks: p.49

- 15) Games committee specifies location, marking material and number of check marks.....6-8-6

Trials: p. 48-50

- 16) Competitors receive a maximum of three (3) trials at each height in order of draw.....6-8-1
- 17) Trials may be passed. Only the number of attempts left will be available.....6-8-1
- 18) Once three (3) consecutive misses occur the contestant is eliminated from the event.....6-8-1
- 19) Contestants who pass three or more consecutive heights with NO attempts are permitted one (1) warm-up jump w/o the crossbar in place and enter at that height
 - The warm-up must be taken at a height change.....6-8-7
- 20) Opening heights will be determined by games committee.....6-8-8
- 21) When only one competitor remains, the event winner can choose the next height.....6-8-8
- 22) An accurate measurement of the bar shall be taken before each record attempt.....6-8-12
- 23) Measurements shall be made to the nearest lesser (¼) INCH or CENTIMETER.....6-8-13

Time Limit: Table on p.41; 42

- 24) FOUR or more competitors ➔ Initiate trial within one (1) min. THREE or less competitors ➔ Initiate trial within three (3) min. SINGLE competitor ➔ Initiate trial within five (5) min.....6-2-2
- 25) Time limit when excused to other events ➔ determined by games committee.....6-2-4

Failed Attempts: p.49

- 26) Displaces crossbar during an attempt to clear.....6-8-11a
- 27) Touches ground/landing area beyond plane of crossbar or its extension w/o clearing bar.....6-8-11b
- 28) Clears height, then contacts upright and displaces (or steadies) crossbar.....6-8-11c
- 29) After x-bar set and name called competitor fails to initiate a trial within one (1) minute.....6-8-11d
- 30) Competitor fails (total body) to go over the crossbar.....6-8-11e
- 31) Competitor takes off from two (2) feet.....6-8-11f

General: p.49

- 32) The crossbar shall not be lowered once the event begins. Exception: 1st place tie.....6-8-9
- 33) If a support ever slips down, the judge will rule 'no jump' and allow another trial.....6-8-4
- 34) A crossbar displaced by an external force after being cleared legally is counted as successful.....6-8-5

Ties: p.44

- 35) 1st tie breaker: fewest number of misses at tied height is winner.....6-3-2b1
- 36) 2nd tie breaker: fewest number of misses during competition is the winner.....6-3-2b2
- 37) Passed trials shall not count as misses.....6-3-2b3
- 38) 3rd tie breaker (**for 1st place only**): Allow (1) more trial at tied height.....6-3-2b4a
 - Tied jumpers both miss ➔ lower the bar 1" and allow (1) trial
 - Tied jumpers both clear ➔ raise the bar 1" and allow (1) trial
 - Continue to raise/lower the bar and allow (1) trial until winner is determined
- 39) Ties below 1st place: add points for places & divide by number of tied competitors.....6-3-4

Landing Area: p.58-60

- 1) Landing pads in sections must be encased in a common cover6-9-26
- 2) The maximum cutout for the planting box shall be 36" in width6-9-27
- 3) Hard surfaces shall be padded with a minimum 2" of dense foam/suitable material6-9-28
- 4) Support bases must be secured or weighted to prevent them from tipping over.....6-9-29
- 5) Width between support pins is $\geq 13'8"$ and $\leq 14'8"$ 6-9-29
- 6) Pole Vault crossbar shall be circular, non-metal and $\geq 14'8"$ and $\leq 14'10"$ in length.....6-9-30
- 7) The X-bar is placed 18" to 31½" beyond the stop board toward the landing pit (Fig 14).....6-8-20

Uniforms: p.23-24

- 8) Competitors must wear shoes fastened securely to both feet..... 4-3-1a
- 9) Competitors must compete in a complete uniform (school issued or school approved).....4-3-1b

Poles: p.50

- 10) Poles may be of any material any of length and diameter6-8-14
- 11) The bottom of pole may be protected tape, PVC, sponge rubber, suitable material.....6-8-14
- 12) Manufacturer's pole rating shall be a minimum of ¾-inch in a contrasting color located within or above top hand-hold position; a one 1-inch circular band placed by the manufacturer to indicate the top handhold position is required.....6-8-15
- 13) Prior to competition, the coach must verify poles meet specifications and that the vaulter is using a pole rated \geq the vaulter's weight.....6-8-15
- 14) Variable weight pole; mismarked pole; lighter rated pole = Illegal = Event DQ.....6-8-16

Warm ups: p.17; 42; 49

- 15) Pole vault warm-up may not start until poles have been inspected & approved for use.....6-8-17
 - 16) Bungee cord crossbars may be used for warm-up vaults.....6-8-3
 - 17) Warm-up must be supervised by official or coach and venue declared open6-2-6
 - 18) Warm-up approaches shall only be run in the direction of competition (see NOTE).....6-2-7
 - 19) Once competition begins, venue and associated equipment is off limits for practice.....6-2-8
 - 20) Event concluded - there will be no further activity - event area is closed.....6-2-9
 - 21) Event concluded – ALL associated equipment INCLUDING POLES is removed from are6-2-9
- 1st Violation ➔ Warning ... 2nd Violation ➔ Event DQ ... 3rd Violation ➔ Meet DQ

Order: p.43; 48

Pole Vault = Girls 1st [even years], Boys 1st [odd years]

- 22) Calling contestants in listed order or using the "Five Alive" system is allowed6-8-2
- 23) When less than 9 remain at a height, ALL will move to a single continuing flight6-8-2
- 24) Order may be changed in any jumping event to allow for participation in other events6-2-3

Check marks: p.51

- 25) Checks marks are not allowed on the runway. They may be placed on the side6-8-21

Grip: p.50-51

- 26) Taping wrists is allowed; Tape NOT allowed on hand unless to cover an open wound6-8-22
- 27) Gloves NOT allowed. The use of a forearm cover to prevent injuries is permitted.....6-8-22
- 28) Chalk or an adhesive such as rosin may be applied to hands or pole6-8-22
- 29) Tape on poles must be of UNIFORM THICKNESS below top hand hold mark6-8-14

Trials: p.48-49; 51-52

- 30) Opening heights will be determined by games committee.....6-8-19
- 31) When only one competitor remains, the event winner may choose the next height.....6-8-19
- 32) Competitors receive a maximum of three (3) trials at each height in order of draw6-8-1
- 33) Trials may be passed. Only the number of attempts left will be available.....6-8-1
- 34) Once three (3) consecutive misses occur the contestant is eliminated from the event6-8-1
- 35) A broken pole during an attempt does not count as a trial6-8-23
- 36) A crossbar displaced by an external force after being cleared legally is counted as successful.....6-8-5
- 37) An accurate measurement of the bar shall be taken before each record attempt.....6-8-28
- 38) Measurements shall be made to the nearest lesser ¼ INCH or CENTIMETER.....6-8-29

Time Limit: Table on p.41; 42

- 39) FOUR or more competitors ➔ Initiate trial within one (1) min. THREE or less competitors ➔ Initiate trial within three (3) min. SINGLE competitor ➔ Initiate trial within five (5) min6-2-2
- 40) Time limit when excused to other events ➔ determined by games committee.....6-2-4

Failed Attempts: p.51-52

- 41) Competitor displaces crossbar with body or pole during an attempt to clear6-8-27a
- 42) Competitor leaves ground and fails to clear. (excludes aborted approaches)6-8-27b
- 43) Uppermost hand is raised above starting point when they leave the ground or lower hand moves above upper hand on the pole6-8-27c
- 44) Body/pole touches ground/landing area beyond plane of stop board before clearing6-8-27d
- 45) Competitor fails to initiate a trial after being called within time limit6-8-27e
- 46) Competitor clears the height, contacts upright and displaces (or steadies) crossbar6-8-27fg
- 47) Competitor grips the pole above the top circular band placed by the manufacturer.....6-8-27h
- 48) Competitor touches (or catches) pole to prevent it from dislodging crossbar.....6-8-27i

General: p.50-52; 49

- 49) No person except competitor, official or designee allowed to touch the pole6-8-25
- 50) The crossbar shall not be lowered once the event begins except for a 1st place tie6-8-26
- 51) Mark the X-Bar and base of the standards to ensure consistent placement.....6-8-28
- 52) If a support is misplaced or slips, this is 'no vault' and another trial will be allowed.....6-8-4
- 53) Contestants who pass three (3) or more consecutive heights with NO attempts are permitted two (2) minutes of warm-up per no. of opponents w/o the crossbar in place Warm up must occur at the height change and contestant(s) enter at that height6-8-18

Ties: p.44

- 54) 1st tie breaker: fewest number of misses at tied height is winner.....6-3-2b1
 - 55) 2nd tie breaker: fewest number of misses during competition is the winner6-3-2b2
 - 56) Passed trials shall not count as misses6-3-2b3
 - 57) 3rd tie breaker (**for 1st place only**): Allow (1) more trial at tied height.....6-3-2b4a
- Tied jumpers both miss ➔ lower the bar 3" and allow (1) trial
Tied jumpers both clear ➔ raise the bar 3" and allow (1) trial
Continue to raise/lower the bar and allow (1) trial until winner is determined
- 58) Ties below 1st place: add points for places & divide by number of tied competitors6-3-4

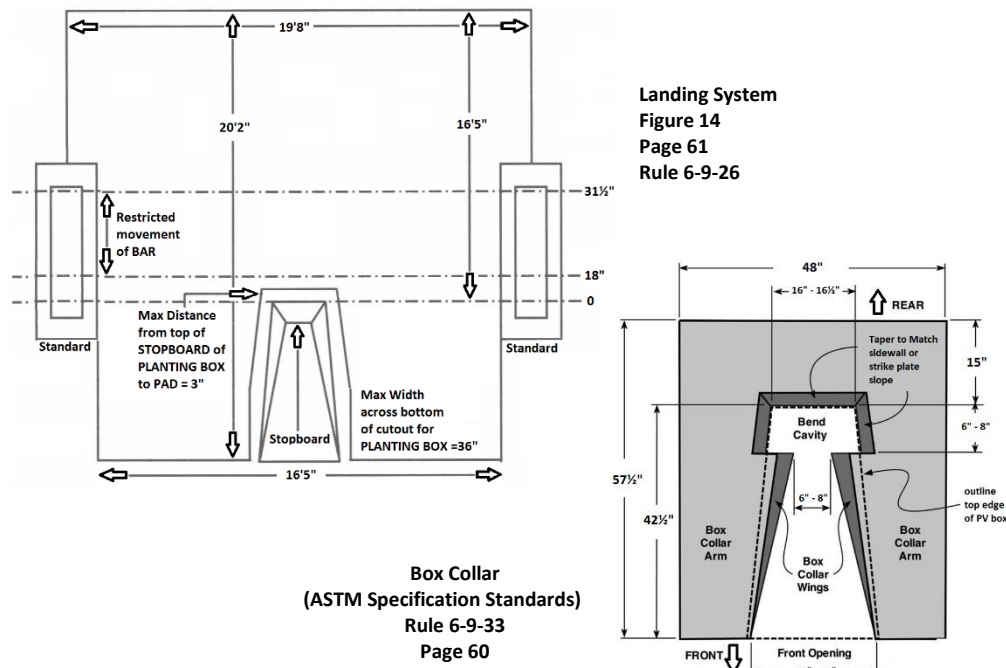

Uniform Guidelines**PROACTIVE CHECK IN**

Athletes may fix their uniforms or tuck in tops before competition begins.

INVISIBLE

Socks; Arm Warmers; HAIR CONTROL; Visor; Waistband Logo;
Undergarments; Gloves in HJ & LJ

VISIBLE & OK

Ski Band; Knit Watch Cap; Ball Cap; Jewelry; Sunglasses; Medic Alert Bracelet;
Watches; Sweatband ≤ 2 " wide; One Mfg Logo per garment $\leq 2\frac{1}{4}$ IN. SQUARE.

VISIBLE & NOT OK:

GLOVES in SP/DT/PV/RELAYS; Offensive Temp Body Adornment or Tattoo;
Bare Midriff; Hazardous Jewelry; Tops w/Knots; Dew Rag; No Shoes;

Failure to Report

A contestant who fails to report before the start of competition shall not be allowed to participate in the event (Rule 4-1-3). Contact the REFEREE.

Athletes Excused to Another Event

- **ASK** Athletes at check-in if they have other events.
- **TIME LIMITS** - Know the procedure set by the *games committee*.
- **COMMON SENSE** must prevail.
- **RE-ORDER FLIGHTS** to facilitate athletes competing in other events.
Athletes may choose to 1) move ahead in the order of competition or 2) take consecutive trials before being excused.
- **BE PROACTIVE** - Allow a teammate or coach to report to a field event to stand by for a competitor who is competing in another event.
The stand-in's presence validates the entry of the excused athlete.
- **TIME-STAMP TWICE** - When excused athlete 1) LEAVES and 2) RETURNS.
- **FINALS** - DO NOT CALL an athlete who is legally excused to another event.
Continue the competition.
NOTE: The competitor with the best prelim mark may wait until any excused competitors have taken all their trials to take the FINAL attempt of the competition (Rule 6-2-3).

Athlete Excused to Another Event - HAS NOT RETURNED**SP, DT, & LJ**

If an athlete has not returned and all others have completed trials ...
ANNOUNCE that all remaining throws or jumps must be completed.
Example: "In 10 minutes (or another pre-defined time) the venue will close."

HJ & PV

If an athlete has not returned and all others have cleared the height ...
ANNOUNCE that the bar will raise.
Example: "In 5 minutes (or another pre-defined time) the bar will raise to the next height." Unused attempts will be marked as a *pass* and may be used at the new height.

Judges Terminology - ALL FIELD EVENTS**CALLING TRIALS**

James '**UP**' | William '**ON DECK**' | Thomas '**ON HOLD**'.

When they are '**UP**,' Competitors must be ready - not getting ready.

GOOD ATTEMPT

'Fair' - or - White Flag (The use of FLAGS is recommended)

FAILED ATTEMPT

'Foul' - or - Red Flag (The use of FLAGS is recommended)

RECORDING TRIALS (HJ & PV)

O ➔ cleared height X ➔ failed attempt - ➔ attempt passed

Order of Competition

- High Jump & Pole Vault ➔ "5 Alive" format.
When less than 9 remain at a height,
ALL will move to a single continuing flight.
- Discus & Shot Put ➔ Regional & State Final will be 1-1-1.

Measuring Attempts

- LJ, HJ, PV, & SP ➔ MEASURE to nearest lesser $\frac{1}{4}$ -INCH or CENTIMETER.
- DISCUS ➔ MEASURE to nearest lesser INCH or CENTIMETER.
- LONG JUMP ➔ MEASURE at the takeoff board not the pit.
- HJ & PV ➔ MEASURE heights before record attempts.

Communication

- **AVOID ANNOUNCING** the name of an athlete or school who's AWOL.
- **CLEARLY ARTICULATE** performance (height/distance) after each trial.
- **RECORD BEST PERFORMANCE** carefully in 'BESTS COLUMN.'
- **ANNOUNCE & CIRCLE** the BEST performances after final attempts.
- **ANNOUNCE** at conclusion of competition - order of finish & best performance.
- **SEND RESULTS** to press box announcer.

Advancing Qualifiers to Finals

- **DOUBLE-CHECK** the score sheet.
- **CONFIRM** the FINALISTS before announcing.
- **SEND FINALS INFO** to press box announcer.
- **ANNOUNCE** - 1) Finalists & best prelim performance.
2) time at which finals begin.
- (optional) **RE-WRITE** the FINALISTS with best prelim mark on another sheet in the order of finals competition.
- Competitors may view video in a coach's box or unrestricted area.

Managing Appeals / Questions (examples: improper attire or implement)

- 1) Record the performance.
- 2) Do not announce results if there is a question or appeal.
- 3) Contact the REFEREE to resolve issue.

Shot Put & Discus Throw

TRIALS at Regional and State Final Meets

from the MHSAA

In the [shot put and discus throw] each competitor shall be allowed three preliminary trials. In the finals, each qualifier is awarded three additional trials [Rule 6-2-17].

Additionally, at MHSAA Regional and State Final meets, these trials shall be taken in the sequence 1-1-1.

Shot Put & Discus Throw

Set-Up of the 34.92-degree Throwing Sector

from The NFHS 2024 Track & Field Rule Book

Appendix B; p. 87 - 88

The degree measure of sectors in both the Shot Put and Discus Throw for 2008 and beyond will be 34.92 degrees.

The Isosceles Triangle Formula: **BASE = 0.6 x LEG**

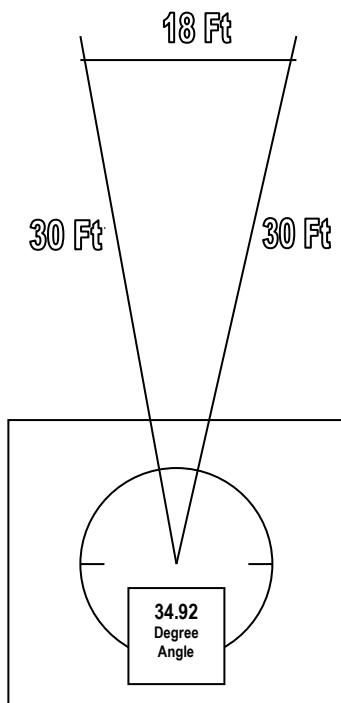

Junior High/Middle School Notes

from the 2023-2024 MHSAA Coaches Guidebook

p. 20

- **PARTICIPATION:** Athlete may participate in any 3 track and/or field events.
- **DUAL MEET SCORING:** 5-3-1 (INDIVIDUAL); 5-0 (RELAYS)
Note: By prior agreement, schools may score 4 places: 5-3-2-1 and 5-0
- Boys run 1st [even year]; Girls run 1st [odd year]

Middle School Hurdle Specifications

from the 2023-2024 MHSAA Coaches Guidebook

p. 20

Note 1:

By mutual consent: Distances may be shortened or events may be eliminated.

Note 2:

55m Hurdles (5 hurdles: Boys Height-33" / Girls Height-30")

START | 13m | 8.5m | 8.5m | 8.5m | 8.5m | 8m | FINISH

Note 3:

200m Hurdles (5 hurdles: Boys Height-30" / Girls Height-30")

Use the 200-meter starting line and common finish line.

START | 50m | 35m | 35m | 35m | 35m | 10m | FINISH

Note 4:

Running Events: One false start shall be permitted (with warning).

Junior High/Middle School Field Event Specifications

from the NFHS 2024 Rule Book

p. 80

Article a)

Boys Discus: 1.0 Kg

Girls Discus: 1.0 Kg

Article b)

Boys Shot Put: 4.0 Kg

Girls Shot Put: 6.0 pounds

Article c)

The **FOUL LINE** in the **LONG JUMP** should be approximately 8-feet from the near edge of the landing pit.

Junior High/Middle School Order of Events – MHSAA Approved List

from the 2023-2024 MHSAA Coaches Guidebook

p. 20

Running Events			Field Events
1. 4x800m	6. 4x100m	11. 200m	Pole Vault
2. 55m LH	7. 400m	12. 3200m	Shot Put
3. 100m	8. 70m	13. 4x400m	High Jump
4. 4x200m	9. 800m		Long Jump
5. 1600m	10. 200 LH		